

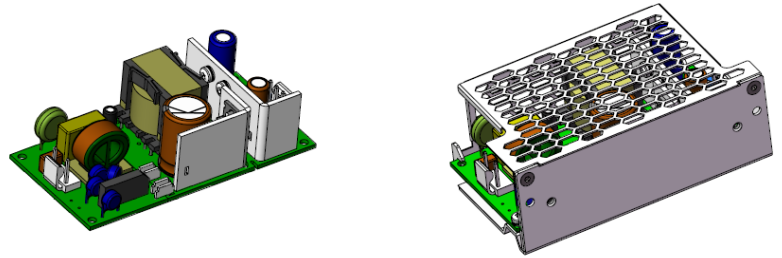

SKY OPEN FRAME



SKY OPEN FRAME

Features

- 1-phase switching mode power supply
- Wide temperature range $-25\text{ }^{\circ}\text{C}$ to $70\text{ }^{\circ}\text{C}$

- Compact Size
- Slim design with metal chassis



- 1.HS1,HS2 cannot be shorted.
- 2.HS1 must have safety isolation distance with system case.

AC Input Connector (CN1) : JST B3P-VH or equivalent

Pin No.	Assignment	Mating Housing	Terminal
1	AC/N	JST VHR or equivalent	JST SVH-21T-P1.1 or equivalent
2	No Pin		
3	AC/L		

DC Output Connector (CN2) : JST B4P-VH or equivalent

Pin No.	Assignment	Mating Housing	Terminal
1,2	+V	JST VHR or equivalent	JST SVH-21T-P1.1 or equivalent
3,4	-V		

⚡ : Grounding Required ;M1 and M2 are Safety ground and should all be grounded.

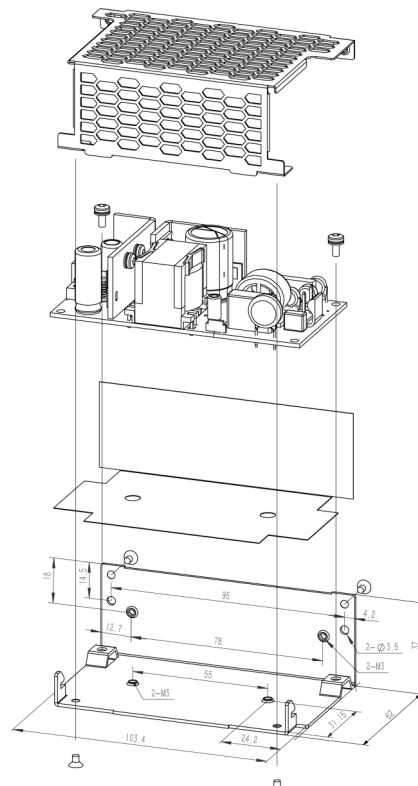
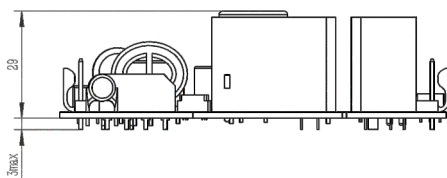
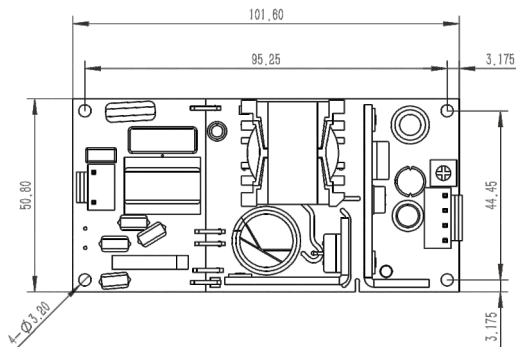
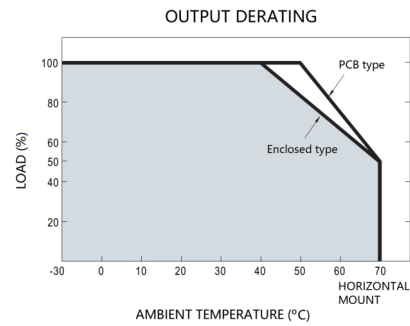



Technical Data

SKY Series Power supply

Parameter	Model non metal casing	WAT-0401-02	WAT-0401-03	WAT-0401-04	WAT-0401-05	WAT-0401-06	WAT-0401-07	WAT-0401-08
	metal casing	WAT-0401-12	WAT-0401-13	WAT-0401-14	WAT-0401-15	WAT-0401-16	WAT-0401-17	WAT-0401-18
Input	Nominal Input Voltage	AC 100 V ... 240 V						
	Extended Input Voltage Range	AC 90 V ... 264V						
	Brown-out / Recovery	No Damage to PSU (Start decreasing < 88Vac)						
	Frequency Range	47 Hz ... 63 Hz						
	Max Input Current	1.8A@115Vac 1A@230Vac						
	Efficiency(Typ) @230V	75 %	79 %	86.5 %	88 %	90.5 %	90.5 %	89.5 %
	Stand-by Losses	<0.5W						
	Leakage Current	<2mA @240Vac						
	Peak Inrush Current	60A@230Vac, cold start @25°C						
	Hold-up Time	16ms at full load@115Vac 50ms@230Vac						
Output	Nominal Output Voltage	5V	7.5V	12V	15V	24V	36V	48V
	Extended Output Voltage Range	4.75~5.5V	7.12~8.25V	10.8~13.5V	13.5~16.5V	21.6~27V	32.4~39.6V	43.2~52.8V
	Output Power (I _A)	30W	40.5W	45W	45W	45W	45W	48W
	Output Current (I _A)	6A	5.4 A	3.75A	3A	1.9A	1.25A	1 A
	Output Regulation Tolerance	±2.0%	±2.0%	±2.0%	±2.0%	±1.0%	±1.0%	±1.0%
	Ripple *Note 1	80mVp-p	100mVp-p	120mVp-p	150mVp-p	240mVp-p	280mVp-p	300mVp-p
	Dynamic Load Response *Note 2	<2%						
	Line Regulation	<0.5%						
	Load Regulation	<1%	<1%	<1%	<0.5%	<0.5%	<0.5%	<0.5%
	Turn-on Delay	<2s at 115Vac, <1s at 230Vac @Full Load						
Protection Function	Signals Power On	LED 1x green						
	Over Current Protection (OCP)	Hiccup, 105%~140% Full load typical						
	Over Voltage Protection	Latched						
	Short Circuit Protection (SCP)	Hiccup, recovers automatically						
Environmental	Over Temperature Protection (OTP)	Hiccup, No Damage						
	Ambient temperature	-25 °C ... +70 °C; Start@-25 °C						
	Temperature derating	-2.5% / K (> 50 °C PCBA only) (> 40 °C Enclosure type)						
	Storage temperature	-25 °C ... +70 °C						
	Humidity	95% non-condensing						
	Pollution degree	2 (gem. EN50178)						
	Climate class	3K3 (EN60721)						
Safety	Height over sea level	4000m						
	Safety class	I						
	Protection class	IP20						
EMC	Over voltage category	II 2000m						
	ESD	Criteria A, EN61000-4-2 air ±8KV , Contact ±6KV						
	Electromagnetic HF field	Criteria A, EN61000-4-3, 80MHz-1GHz, 10V/m, 2GHz-3GHz 10V/m						
	Fast transient (Burst)	Criteria B, EN61000-4-4 1kV						
	Surge	Criteria B, EN61000-4-5 2kV com; 1 kVdiff						
	Conducted interference	Criteria A, EN61000-4-6 (150kHz-80MHz), 10V						
	Mains variation	Dip 70% 0.5cycle, Crit B Dip 40%, 5 cycle, Crit C Dip <5%, 250cycles 50Hz, Crit C, EN61000-4-11 voltage dip						
Emission	Conducted EMI	Class B, EN55032 (CISPR32) 150kHz-30MHz, FCC						
	Radiated EMI	Class B, EN55032 (CISPR32) 30M-1GHz, FCC						
	Harmonic current	Class A, EN61000-3-2 harmonic current						
Connectors	AC	L/N/Earth, Conductor cross section (26~16AWG, 0.2~1.5mm ²), strip length 8mm						
	DC	Output terminal+/-, Conductor cross section (26~16AWG, 0.2~1.5mm ²), strip length 8mm						
Other	MTBF	500k hrs, 500.000h (gem. SN29500)						
	Max Sizes (mm) D X W X H	PCB:102*51*29(LxWxH);						
	Weight	125g (non metal casing) /245g (metal casing)						
Note	<p>*Note 1: 20MHz bandwidth, measured with a 1uF MLCC and a 100uF E-Cap.</p> <p>*Note 2: 0.6 slew rate A/us 100Hz or 1k; 50% duty</p> <p>*Note 3: Chassis version normally are with better EMC performance. So for final product with non metal casing better use chassis version.</p>							